

# ESD Suppressor : LCP Series

Ultra-Low Capacitance ESD Suppressor for High-Speed Application



## ■ Features

1. RoHS compliant and lead-free
2. EIA size: 0402, 0603
3. Ultra-low capacitance (<0.2pF) and low leakage current (<0.05uA)
4. Fast response time (<1ns)
5. Bi-directional device
6. Rate for ESD protection and pass IEC 61000-4-2 level 4 test

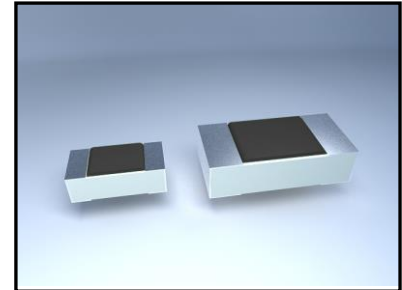

## ■ Recommended Applications

1. High-Speed Data Lines (HDMI, Serial ATA, USB, IEEE1394)
2. Antenna Circuit (Cellular phone, GPS...)
3. Digital Cameras
4. Set-Top Boxes
5. Printer Ports

## ■ Part Number Code

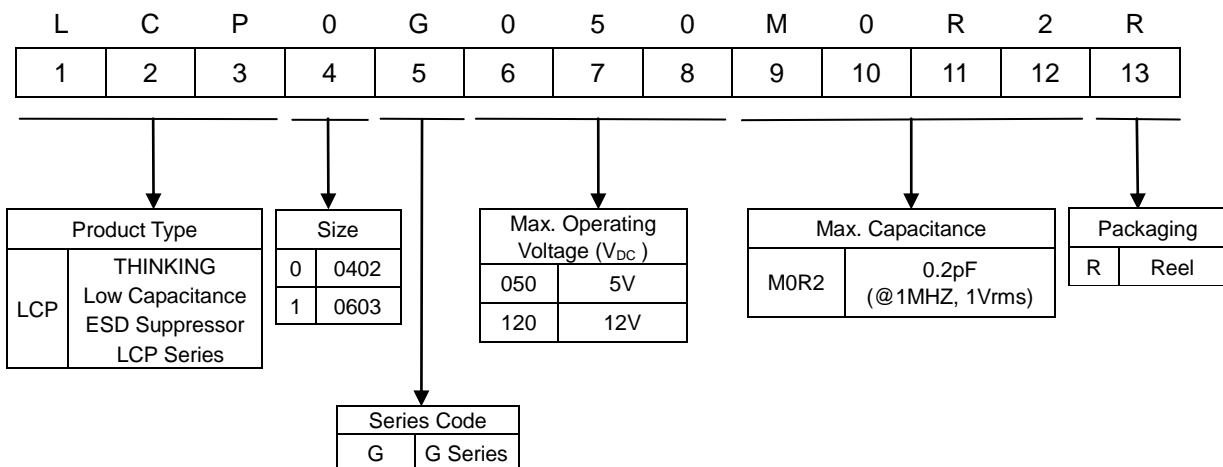

# ESD Suppressor : LCP Series

Ultra-Low Capacitance ESD Suppressor for High-Speed Application



## ■ Structures and Dimensions

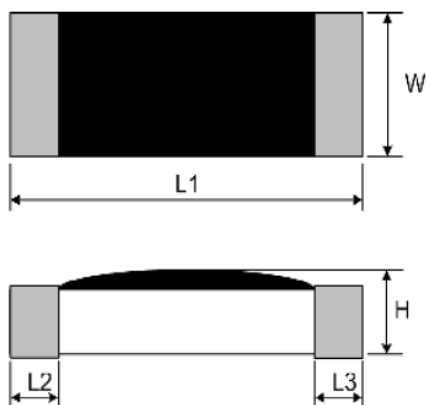

(Unit: mm)

Part No.	Size (EIA)	L1	W	H	L2 and L3
LCP0G	0402	$1.00 \pm 0.15$	$0.50 \pm 0.10$	$0.35 \pm 0.10$	$0.20 \pm 0.10$
LCP1G	0603	$1.60 \pm 0.15$	$0.80 \pm 0.15$	$0.50 \pm 0.10$	$0.35 \pm 0.15$

# ESD Suppressor : LCP Series

Ultra-Low Capacitance ESD Suppressor for High-Speed Application



## ■ Electrical Characteristics

Part No.	Size	Max. Operating Voltage	Typical Trigger Voltage (*1)	Max. Capacitance @1MHZ, 1Vrms	Clamping Voltage @8KV, 30ns (*2)		Max. Leakage Current @V <sub>DC</sub>	Min. ESD Pulse Withstand	Insulation Resistance	Operating Temperature Range
		V <sub>DC</sub> (V)	V <sub>T</sub> (V)	C (pF)	V <sub>c</sub> (V)		I <sub>L</sub> (μA)	Times	R(MΩ)	(°C)
					Typical	Max.				
LCP0G3R3M0R2	0402	3.3	300	0.2	30	100	0.05	1000	>100	-40 ~ +85
LCP0G050M0R2	0402	5	300	0.2	30	100	0.05	1000	>100	-40 ~ +85
LCP0G060M0R2	0402	6	300	0.2	50	100	0.05	1000	>100	-40 ~ +85
LCP0G100M0R2	0402	10	360	0.2	50	100	0.05	1000	>100	-40 ~ +85
LCP0G120M0R2	0402	12	360	0.2	50	100	0.05	1000	>100	-40 ~ +85
LCP0G140M0R2	0402	14	390	0.2	50	100	0.05	1000	>100	-40 ~ +85
LCP0G150M0R2	0402	15	390	0.2	50	100	0.05	1000	>100	-40 ~ +85
LCP0G180M0R2	0402	18	390	0.2	50	100	0.05	500	>100	-40 ~ +85
LCP0G200M0R2	0402	20	420	0.2	50	100	0.05	500	>100	-40 ~ +85
LCP0G240M0R2	0402	24	420	0.2	50	100	0.05	500	>100	-40 ~ +85
LCP0G300M0R2	0402	30	450	0.2	50	100	0.05	500	>100	-40 ~ +85
LCP1G3R3M0R2	0603	3.3	300	0.2	30	100	0.05	1000	>100	-40 ~ +85
LCP1G050M0R2	0603	5	300	0.2	30	100	0.05	1000	>100	-40 ~ +85
LCP1G060M0R2	0603	6	300	0.2	50	100	0.05	1000	>100	-40 ~ +85
LCP1G100M0R2	0603	10	360	0.2	50	100	0.05	1000	>100	-40 ~ +85
LCP1G120M0R2	0603	12	360	0.2	50	100	0.05	1000	>100	-40 ~ +85
LCP1G140M0R2	0603	14	390	0.2	50	100	0.05	1000	>100	-40 ~ +85
LCP1G150M0R2	0603	15	390	0.2	50	100	0.05	1000	>100	-40 ~ +85
LCP1G180M0R2	0603	18	390	0.2	50	100	0.05	500	>100	-40 ~ +85
LCP1G200M0R2	0603	20	420	0.2	50	100	0.05	500	>100	-40 ~ +85
LCP1G240M0R2	0603	24	420	0.2	50	100	0.05	500	>100	-40 ~ +85

Note 1: Typical Trigger Voltage (V<sub>T</sub>) follows IEC 61000-4-2, Level 4 and maximum peak voltage shall be measured after initiation of pulse.

Note 2: Clamping Voltage (V<sub>c</sub>) follows IEC 61000-4-2, Level 4 and voltage value shall be measured at 30ns after initiation of pulse.

# ESD Suppressor : LCP Series



## Ultra-Low Capacitance ESD Suppressor for High-Speed Application

### ■ Soldering Recommendation

#### ● IR-Reflow Soldering Profile

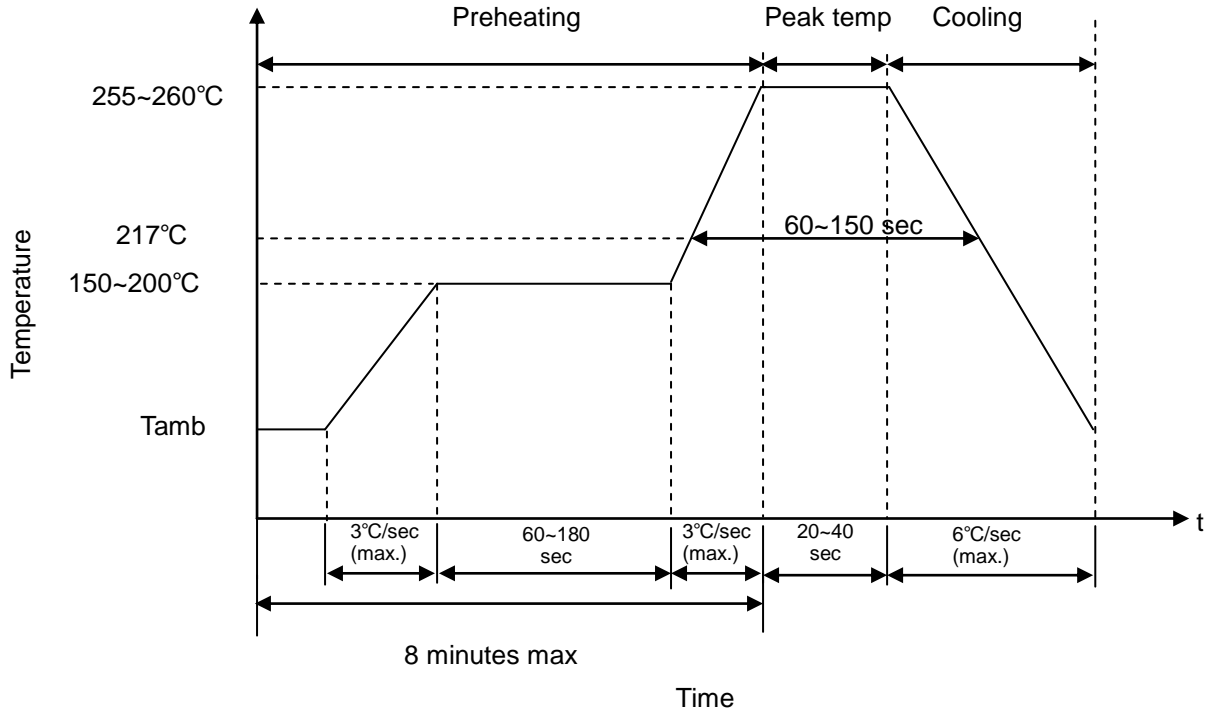

### ■ Recommended Reworking Conditions with Soldering Iron

Item	Conditions
Temperature of Soldering Iron-tip	360°C (max.)
Soldering Time	3 sec (max.)
Diameter of Soldering Iron-tip	Φ3mm (max.)

Caution: Please do not directly touch the component surface with soldering iron to avoid its damage.

### ■ Recommended Soldering Pad Dimensions

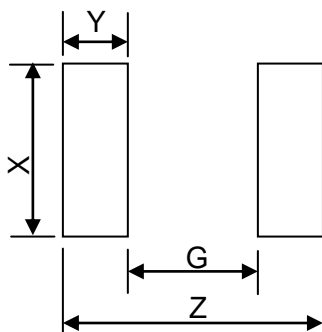

Size (EIA)	Z (mm)	G (mm)	X (mm)	Y (mm)
0402	1.7	0.5	0.6	0.6
0603	2.8	0.8	1.0	1.0

# ESD Suppressor : LCP Series

Ultra-Low Capacitance ESD Suppressor for High-Speed Application



## ■ Electrostatic Discharge-ESD Reliability

Severity Level	Discharge Voltage	Initial Current	30 ns Current	60 ns Current
1	2 kV	7.5 A	4A	2A
2	4 kV	15.0 A	8A	4A
3	6 kV	22.5 A	12A	6A
4	8 kV	30.0 A	16A	8A

\* Follow IEC61000-4-2

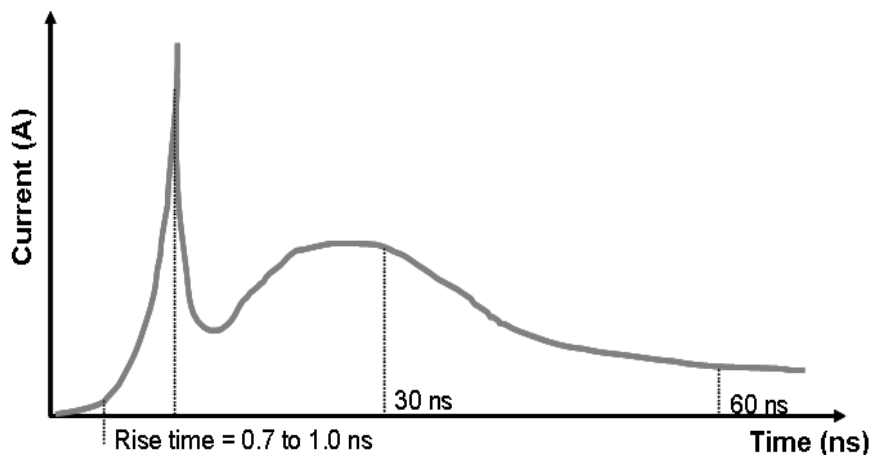

## ■ Reliability

Item	Standard	Test conditions / Methods	Specifications															
Resistance to Soldering Heat	IEC 60068-2-58	260 ± 5 °C, 10 ± 1 sec	$I_L \leq 10\mu A$ No visible damage															
High Temperature Load	MIL-STD-202 Method 108	85 ± 2 °C, 1000±24 hrs at $V_{DC}$	$I_L \leq 10\mu A$ No visible damage															
Damp Heat Load, Steady State	IEC 60068-2-78	40±2°C, 90-95%RH, 1000±24hrs, at $V_{DC}$	$I_L \leq 10\mu A$ No visible damage															
Rapid Change of Temperature	IEC 60068-2-14	The conditions shown below shall be repeated 5 cycles on PCB <table border="1" style="margin-left: 20px;"> <thead> <tr> <th>Step</th> <th>Temperature (°C)</th> <th>Period (minutes)</th> </tr> </thead> <tbody> <tr> <td>1</td> <td>-40</td> <td>30 ± 3</td> </tr> <tr> <td>2</td> <td>Room temperature</td> <td>5 ± 3</td> </tr> <tr> <td>3</td> <td>85</td> <td>30 ± 3</td> </tr> <tr> <td>4</td> <td>Room temperature</td> <td>5 ± 3</td> </tr> </tbody> </table>	Step	Temperature (°C)	Period (minutes)	1	-40	30 ± 3	2	Room temperature	5 ± 3	3	85	30 ± 3	4	Room temperature	5 ± 3	$I_L \leq 10\mu A$ No visible damage
Step	Temperature (°C)	Period (minutes)																
1	-40	30 ± 3																
2	Room temperature	5 ± 3																
3	85	30 ± 3																
4	Room temperature	5 ± 3																

# ESD Suppressor : LCP Series



Ultra-Low Capacitance ESD Suppressor for High-Speed Application

## ■ Packaging

### ● Taping Specification (0402 types)

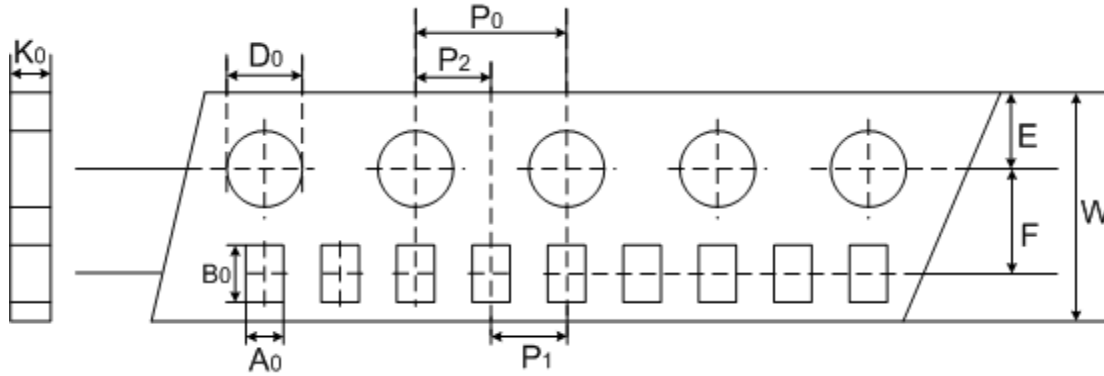

Index Type	A <sub>0</sub>	B <sub>0</sub>	W	E	F	P <sub>1</sub>	P <sub>2</sub>	P <sub>0</sub>	D <sub>0</sub>	K <sub>0</sub>
0402	±0.05	±0.12	±0.2	±0.1	±0.05	±0.1	±0.05	±0.1	±0.1	±0.1

### ● Taping Specification (0603 type)

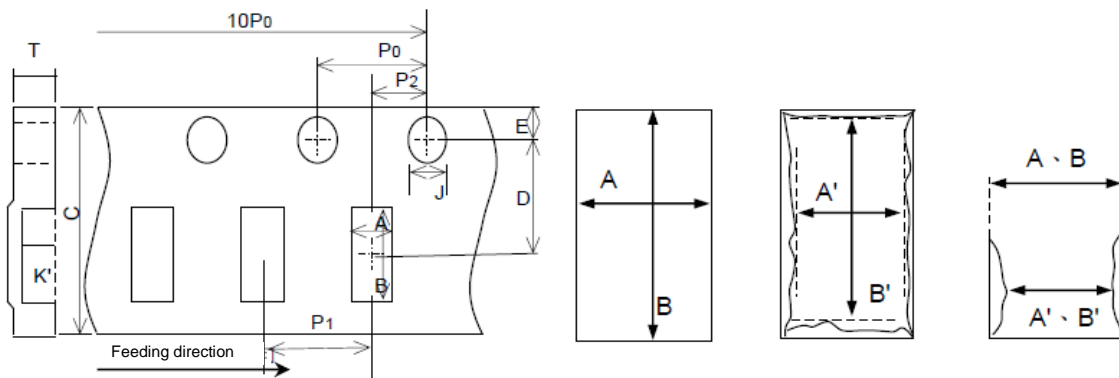

Index Type	A	B	C	D	E	P <sub>0</sub>	P <sub>1</sub>	P <sub>2</sub>	J	K'	T	10P <sub>0</sub>
0603	±0.05	±0.05	±0.01	±0.05	±0.1	±0.1	±0.1	±0.05	±0.05	±0.03	±0.05	±0.1

# ESD Suppressor : LCP Series

Ultra-Low Capacitance ESD Suppressor for High-Speed Application



## ■ Quantity

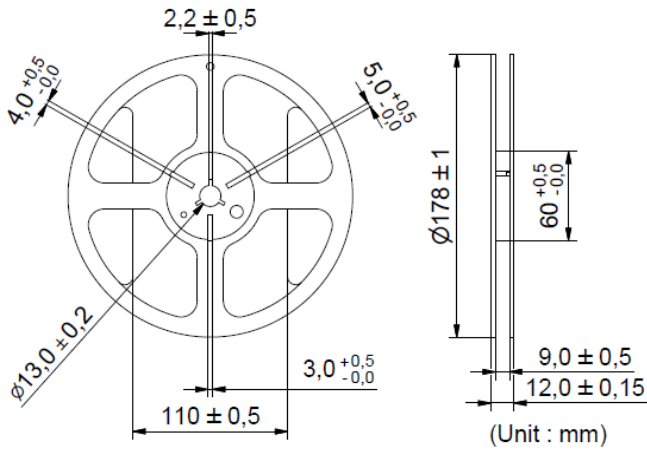

### ● Reel Packaging

Type	Quantity (pcs/reel)
0402	10,000
0603	4,000

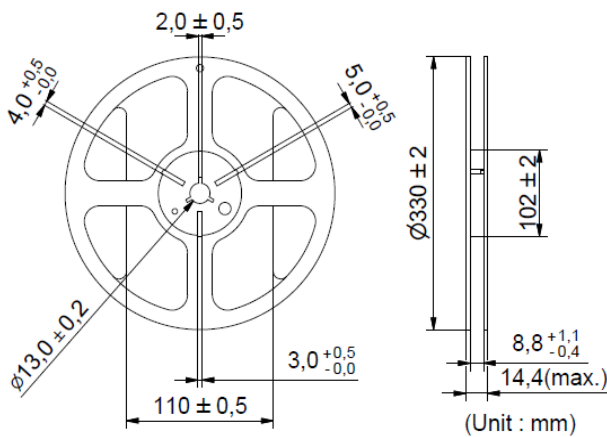

### ● Reel Packaging

Type	Quantity (pcs/reel)
0402	50,000
0603	16,000

## ■ Warehouse Storage Conditions of Products

### ● Storage Conditions :

1. Storage Temperature : -10°C~+40°C
2. Relative Humidity : ≤75%RH
3. Keep away from corrosive atmosphere and sunlight.

### ● Period of Storage: 1 year